

MY 5000

STEAM AND VACUUM CAPPING MACHINE « EURO-TWIST »®

photo non contractuelle

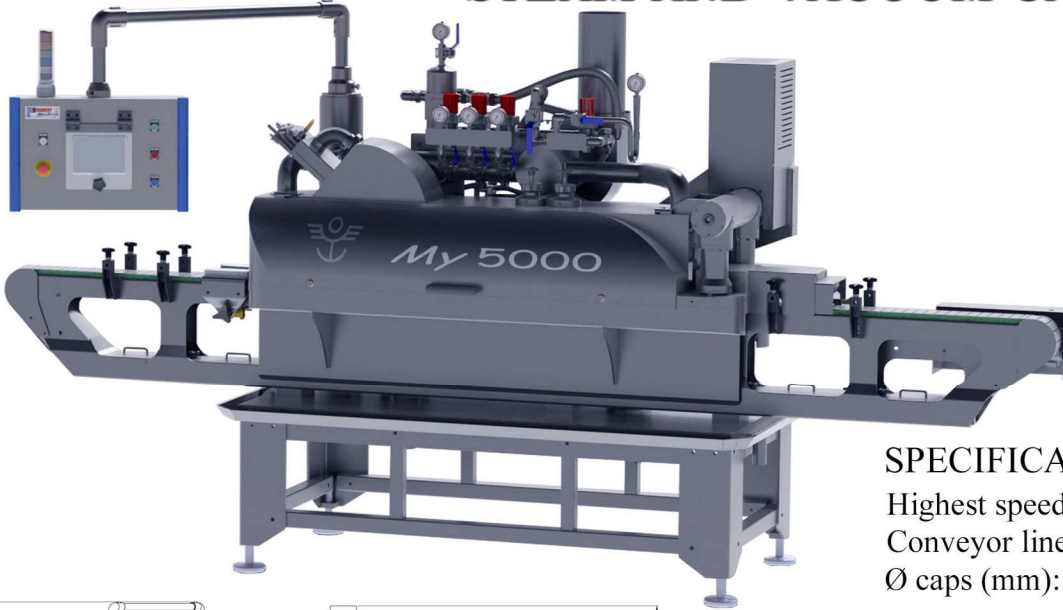

SPECIFICATIONS

Highest speed: 500 jars/min
Conveyor linear speed: 80m/min
Ø caps (mm): Ø38* mini-Ø82 maxi
Ø100-Ø110 (see us)
Ø jars : Ø38 mini to Ø110 maxi
Jars height: 50 to 266 mm
Workstation height: 0.83m to 1.3m
Cross weight: 1250 Kg

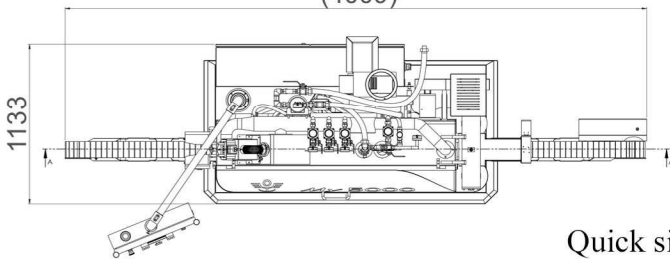
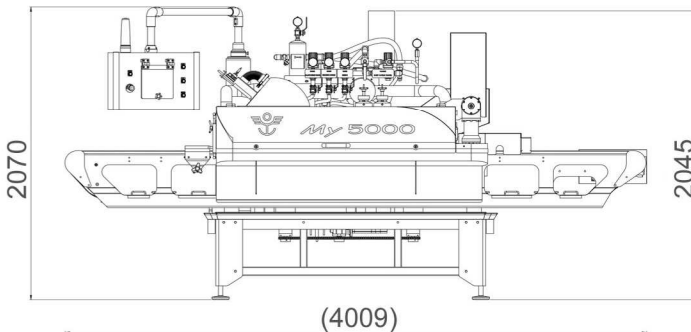

OPTIONS

Conveyor length extension «input side»
Caps feeding elevator
Screwing: single belt and shoe or double belt.
Vacuum detector
Possibility of symmetrical machine

IMPROVEMENTS

Quick size change..
Control by touch screen7”.
Automatic adjustment of heigh and tightening at of the brackets by recipe.
Automatic maintenance position.
Energy save mode.
Finer brackets new generation.

* One pick up head / diameter

Massilly 
SERVICES

Massilly 

MANUFACTURING OF METAL PACKING FOR
FOOD PRODUCTS