



Massilly 

North America Inc.

MY 2000 VACUUM STEAM SEALING MACHINE

Massilly capping machines provide superior performance and durability, adding a valuable component to any production line.

The MY 2000 features:

- **Safety:** built-in safety features that prevent injuries
- **Flexibility:** quick set up and change over; adapts to individual production requirements
- **Reliability:** durable stainless steel construction; easily accessible for cleaning and maintenance
- Fast production rate & larger jar height compatibility
- Excellent vacuum and sealing performance

Note: MY 2000 is supplied with a floor cap elevator.

See specifications on back.



Massilly North America Inc. provides quality sealing equipment and metal twist closures to the food and beverage industry and a variety of other glass packaging manufacturers throughout Canada, the USA, Mexico and South America. Massilly North America Inc. is a member of The Massilly Group, a leading global supplier of closures, food cans, decorative tins, and aerosol cans.

Massilly North America

501 Lakeshore Road East
Mississauga, Ontario, Canada, L5G 1H9
T. 905.271.0311 F. 905.271.2984

Email: customerservice@massilly.ca www.massilly.ca

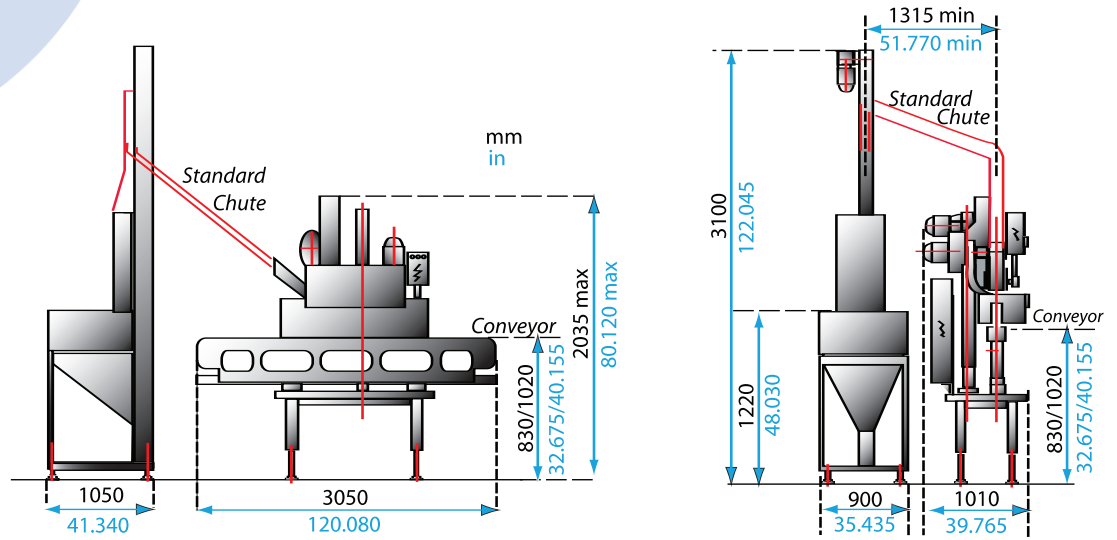

MY 2000 VACUUM STEAM SEALING MACHINE

OPERATIONAL SPECIFICATIONS

CAP TYPE	CAP DIAMETER (mm)	NOMINAL RATE (jars per min.)	JAR DIAMETER (mm)	JAR HEIGHT (mm)
Twist cap	30 to 38*	435	from 30 to 168	from 40 to 300
	43 to 63	285		
	66 to 82	220		
	89 to 110*	165		
Deep Skirt	Dedicated tooling			

* Dedicated tooling

MACHINE SPECIFICATIONS

Weight	850 kg or 1,875 lbs
Length	3050 mm or 10' 1"
Width	1010 mm or 6' 5"
Height	2035 mm or 80.120" max
Conveyor Height	830 mm to 1,020 mm 32.675" to 40.155"

Massilly North America

501 Lakeshore Road East
Mississauga, Ontario, Canada, L5G 1H9
T. 905.271.0311 F. 905.271.2984
Email: customerservice@massilly.ca

www.massilly.ca