

Massilly

North America Inc.

FLOOR CAP ELEVATOR FOR MY 2000 & 5000

The Massilly Floor Cap Elevator provides superior performance and durability, adding a valuable component to any production line.

The Floor Cap Elevator features:

- **Safety:** built-in safety features that prevent injuries
- **Flexibility:** quick set up and change over; adapts to individual production requirements
- **Reliability:** durable stainless steel construction; easily accessible for cleaning and maintenance
- High speed operation that enhances your on-time production demands

Note: The floor cap elevator is supplied with the MY 2000 and 5000 sealing machines. See specifications on back.



Massilly North America Inc. provides quality sealing equipment and metal twist closures to the food and beverage industry and a variety of other glass packaging manufacturers throughout Canada, the USA, Mexico and South America. Massilly North America Inc. is a member of The Massilly Group, a leading global supplier of closures, food cans, decorative tins, and aerosol cans.

Massilly North America

501 Lakeshore Road East
Mississauga, Ontario, Canada, L5G 1H9
T. 905.271.0311 F. 905.271.2984

Email: customerservice@massilly.ca www.massilly.ca

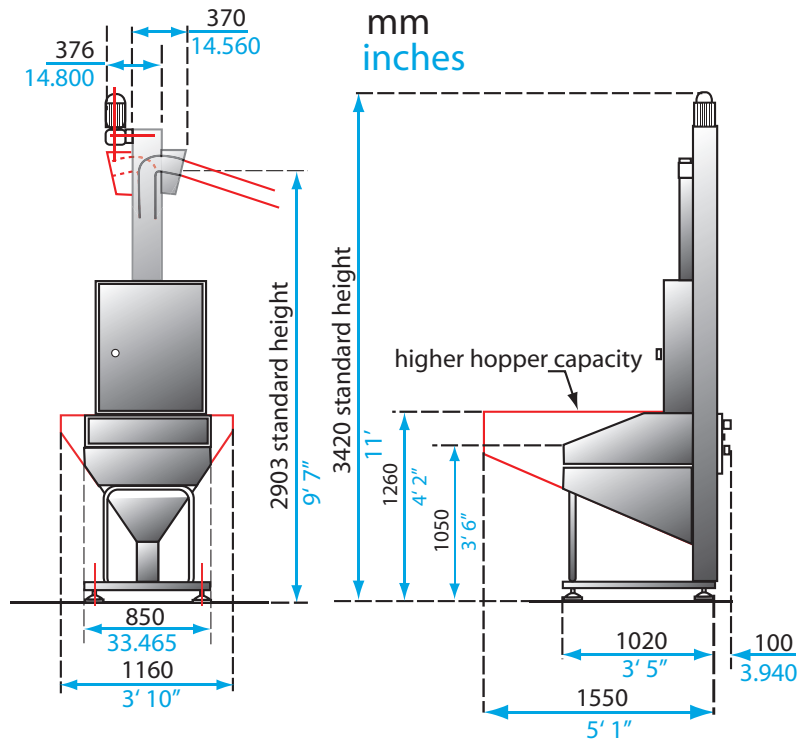

FLOOR CAP ELEVATOR

FOR MY 2000 & 5000

MACHINE & OPERATIONAL SPECIFICATIONS

RUNNING SPEED	SPECIFICATIONS	OPTIONS
Maximum 670 caps per minute	Weight 250 kg or 552 lb	<ol style="list-style-type: none"> Left- or right-end feed Adjustable end feed height Custom connection chute Higher hopper capacity (7 to 8 boxes)
	Length 1120 mm or 3' 5"	
	Width 850 mm or 33.465"	
	Height 3420 mm or 11' max	
	Caps diameter 33 mm to 110 mm	
	Speed regulator on electrical panel	
	Capacity 4 boxes	